

* Ключ : ① : Крепёжный винт, ② : Винт резца

ЗАПАСНЫЕ ЧАСТИ

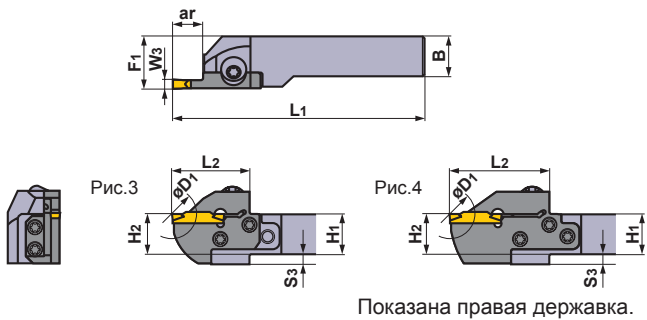

Державка			
	Крепёжный винт	Винт резца (5 штук)	Ключ *
GYHR/L1616J00-M20R/L		TS407 (Момент затяжки : 3.5N·м)	①TKY30R ②TKY15D
GYHR/L2020K00-M20R/L			
GYHR/L2020K00-M25R/L	GY06013M (Момент затяжки : 6.0N·м)	TS55 (Момент затяжки : 5.0N·м)	①TKY30R ②TKY25D
GYHR/L2525M00-M25R/L			
GYHR/L3225P00-M25R/L			
GYHR/L3232P00-M25R/L			

Размеры (мм) *3								Рис.	Условия резания		Пластина	
H1	B	L1	L2	H2	F1	S3	против часовой стрелки		Против часовой стрелки	Геометрия / Обозначение пластины	Страница	
16	16	104	28	16	20	4	3			GY2M0239E020N-GU GY2M0250E020N-GU	F014 -016	
16	16	110	34	16	20	4	3					
16	16	116	40	16	20	4	4					
20	20	119	28	20	23	-	1					
20	20	125	34	20	23	-	1					
20	20	131	40	20	23	-	2					
20	20	117	31	20	26	5	3					
20	20	125	39	20	26	5	3					
20	20	131	45	20	26	5	4					
25	25	142	31	25	28	-	1					
25	25	150	39	25	28	-	1					
25	25	156	45	25	28	-	2					
32	25	162	31	32	28	-	5					
32	25	170	39	32	28	-	5					
32	25	176	45	32	28	-	6					
32	32	162	31	32	35	-	5					
32	32	170	39	32	35	-	5					
32	32	176	45	32	35	-	6					
16	16	104	28	16	20	4	3			GY2G0239E020N-MF GY2G0250E020N-MF GY2G0274E020N-MF		
16	16	110	34	16	20	4	3					
16	16	116	40	16	20	4	4					
20	20	119	28	20	23	-	1					
20	20	125	34	20	23	-	1					
20	20	131	40	20	23	-	2					
20	20	117	31	20	26	5	3					
20	20	125	39	20	26	5	3					
20	20	131	45	20	26	5	4					
25	25	142	31	25	28	-	1					
25	25	150	39	25	28	-	1					
25	25	156	45	25	28	-	2					
32	25	162	31	32	28	-	5					
32	25	170	39	32	28	-	5					
32	25	176	45	32	28	-	6					
32	32	162	31	32	35	-	5					
32	32	170	39	32	35	-	5					
32	32	176	45	32	35	-	6					
										GY2M0250E020R05-GM GY2M0250E020L05-GM		
										GY2M0239E020N-GM GY2M0250E020N-GM (калибровочная пластина)		
										GY2M0250E020N-MS		
										GY2M0250E020N-MM		
										GY2M0250E125N-BM		
										GY1G0239E020N-GFGS GY1G0250E020N-GFGS		

ТОЧЕНИЕ КАНАВОК

ОБОЗНАЧЕНИЕ > F012, F013
РЕЖИМЫ РЕЗАНИЯ > F040
ЗАПАСНЫЕ ЧАСТИ > M001