

* Ключ : ① : Крепёжный винт, ② : Винт резца

ЗАПАСНЫЕ ЧАСТИ

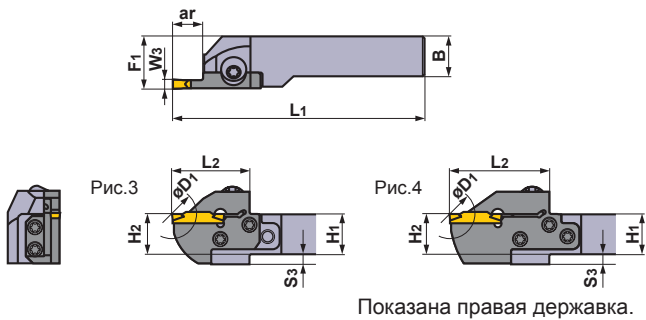

Державка			
	Крепёжный винт	Винт резца (5 штук)	Ключ *
GYHR/L1616J00-M20R/L		TS407 (Момент затяжки : 3.5N·м)	①TKY30R ②TKY15D
GYHR/L2020K00-M20R/L			
GYHR/L2020K00-M25R/L	GY06013M (Момент затяжки : 6.0N·м)	TS55 (Момент затяжки : 5.0N·м)	①TKY30R ②TKY25D
GYHR/L2525M00-M25R/L			
GYHR/L3225P00-M25R/L			
GYHR/L3232P00-M25R/L			

Размеры (мм) *3								Рис.	Условия резания		Пластина	
H1	B	L1	L2	H2	F1	S3	против часовой стрелки		Против часовой стрелки	Геометрия / Обозначение пластины	Страница	
16	16	110	34	16	20	4	3			GY2M0400G030N-GU GY2M0400G020N-GS GY2M0400G030N-GM (калибровочная пластина) GY2M0400G030R05-GM GY2M0400G030L05-GM GY2G0400G020N-MF GY2G0400G040N-MF GY2G0400G080N-MF GY2G0424G020N-MF	F014 -016	
20	20	125	34	20	23	—	1					
20	20	119	33	20	26	5	3					
20	20	125	39	20	26	5	3					
20	20	136	50	20	26	5	4					
25	25	144	33	25	28	—	1					
25	25	150	39	25	28	—	1					
25	25	161	50	25	28	—	2					
32	25	164	33	32	28	—	5					
32	25	170	39	32	28	—	5					
32	25	181	50	32	28	—	6					
32	32	164	33	32	35	—	5					
32	32	170	39	32	35	—	5					
32	32	181	50	32	35	—	6					
16	16	110	34	16	20	4	3			GY2M0400G020N-MS GY2M0400G040N-MS GY2M0400G020N-MM GY2M0400G040N-MM GY2M0400G080N-MM GY2M0400G200N-BM GY1G0400G020N-GFGS	F014 -016	
20	20	125	34	20	23	—	1					
20	20	119	33	20	26	5	3					
20	20	125	39	20	26	5	3					
20	20	136	50	20	26	5	4					
25	25	144	33	25	28	—	1					
25	25	150	39	25	28	—	1					
25	25	161	50	25	28	—	2					
32	25	164	33	32	28	—	5					
32	25	170	39	32	28	—	5					
32	25	181	50	32	28	—	6					
32	32	164	33	32	35	—	5					
32	32	170	39	32	35	—	5					
32	32	181	50	32	35	—	6					

ТОЧЕНИЕ КАНАВОК

ОБОЗНАЧЕНИЕ > F012, F013
 РЕЖИМЫ РЕЗАНИЯ > F040
 ЗАПАСНЫЕ ЧАСТИ > M001