

● Модульный тип (Внутренний подвод СОЖ / воздуха)

* Ключ : ① : Крепёжный винт, ② : Винт резца

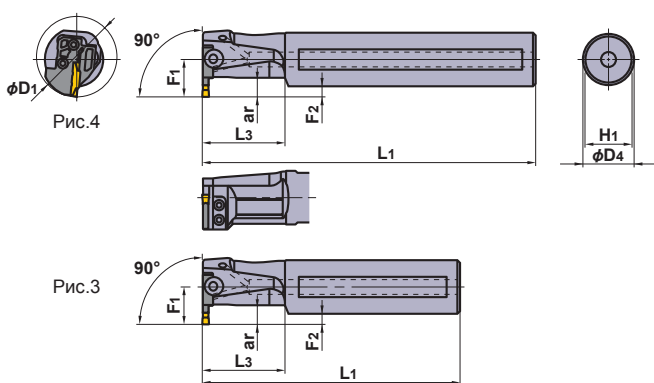

ЗАПАСНЫЕ ЧАСТИ			
Державка			
	Крепёжный винт	Винт резца (4 штуки)	Ключ *
GYAR/L20○90A-○06	GY05016S (Момент затяжки : 5.0N·m)	—	①TKY20R
GYAR/L25○90B-○06	GY06013M (Момент затяжки : 6.0N·m)	TS407 (Момент затяжки : 3.5N·m)	①TKY30R ②TKY15D
GYDR/L32○90C-M20L/R	GY06013M (Момент затяжки : 6.0N·m)	TS55 (Момент затяжки : 5.0N·m)	①TKY30R ②TKY25D
GYDR/L40○90D-M25L/R	GY06013M (Момент затяжки : 6.0N·m)	—	—
GYDR/L50○90F-M25L/R	—	—	—

Размеры (мм) *2							Рис.	Условия резания	Пластина	
D4	L1	L3	F1	F2	H1	Геометрия / Обозначение пластины			Страница	
20	125	30	14.5	4.5	18	1			GY2M0200D020N-GU GY2M0200D020N-GS GY2M0200D020N-GM (калибровочная пластина) GY2G0200D020N-MF GY2G0224D015N-MF	F014 —016
20	180	30	14.5	4.5	18	2				
25	125	40	19	6.5	23	1				
25	200	40	19	6.5	23	2				
32	140	50	22	6.0	30	3				
32	250	50	22	6.0	30	4				
40	150	60	28	8.0	37	3				
40	300	60	28	8.0	37	4				
40	150	60	28	8.0	37	3				
40	300	60	28	8.0	37	4				
50	170	80	34	9.0	47	3				
50	300	80	34	9.0	47	4				
20	125	30	14.5	4.5	18	1			GY2M0200D020N-MS GY2M0200D020N-MM GY2M0200D100N-BM GY1G0200D020N-GFGS	F014 —016
20	180	30	14.5	4.5	18	2				
25	125	40	19	6.5	23	1				
25	200	40	19	6.5	23	2				
32	140	50	22	6.0	30	3				
32	250	50	22	6.0	30	4				
40	150	60	28	8.0	37	3				
40	300	60	28	8.0	37	4				
40	150	60	28	8.0	37	3				
40	300	60	28	8.0	37	4				
50	170	80	34	9.0	47	3				
50	300	80	34	9.0	47	4				
20	125	30	14.5	4.5	18	1			GY2M0239E020N-GU GY2M0250E020N-GU GY2M0239E020N-GS GY2M0250E020N-GS GY2M0239E020N-GM GY2M0250E020N-GM (калибровочная пластина) GY2G0239E020N-MF GY2G0250E020N-MF GY2G0274E020N-MF	F014 —016
20	180	30	14.5	4.5	18	2				
25	125	40	19	6.5	23	1				
25	200	40	19	6.5	23	2				
32	140	50	22	6.0	30	3				
32	250	50	22	6.0	30	4				
40	150	60	28	8.0	37	3				
40	300	60	28	8.0	37	4				
40	150	60	28	8.0	37	3				
40	300	60	28	8.0	37	4				
50	170	80	34	9.0	47	3				
50	300	80	34	9.0	47	4				
20	125	30	14.5	4.5	18	1			GY2M0250E020N-MS GY2M0250E020N-MM GY2M0250E125N-BM GY1G0239E020N-GFGS GY1G0250E020N-GFGS	F014 —016
20	180	30	14.5	4.5	18	2				
25	125	40	19	6.5	23	1				
25	200	40	19	6.5	23	2				
32	140	50	22	6.0	30	3				
32	250	50	22	6.0	30	4				
40	150	60	28	8.0	37	3				
40	300	60	28	8.0	37	4				
40	150	60	28	8.0	37	3				
40	300	60	28	8.0	37	4				
50	170	80	34	9.0	47	3				
50	300	80	34	9.0	47	4				

ТОЧЕНИЕ КАНАВОК

ОБОЗНАЧЕНИЕ > F012, F013
РЕЖИМЫ РЕЗАНИЯ > F118
ЗАПАСНЫЕ ЧАСТИ > M001