

● Модульный тип (Внутренний подвод СОЖ / воздуха)

* Ключ : ① : Крепёжный винт, ② : Винт резца

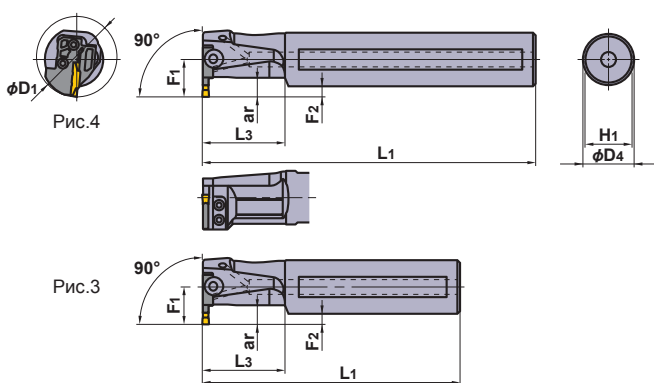

ЗАПАСНЫЕ ЧАСТИ			
Державка			
	Крепёжный винт	Винт резца	Ключ *
GYAR/L25○90B-○07	GY05016S (Момент затяжки : 5.0N·m)	—	①TKY20R
GYDR/L32○90C-M20L/R	GY06013M (Момент затяжки : 6.0N·m)	TS407 (Момент затяжки : 3.5N·m)	①TKY30R ②TKY15D
GYDR/L40○90D-M20L/R	GY06013M (Момент затяжки : 6.0N·m)	TS55 (Момент затяжки : 5.0N·m)	①TKY30R ②TKY25D
GYDR/L40○90D-M25L/R	GY06013M (Момент затяжки : 6.0N·m)	TS55 (Момент затяжки : 5.0N·m)	①TKY30R ②TKY25D
GYDR/L50○90F-M25L/R	GY06013M (Момент затяжки : 6.0N·m)	TS55 (Момент затяжки : 5.0N·m)	①TKY30R ②TKY25D

Размеры (мм) *2							Рис.	Условия резания	Пластина	
D4	L1	L3	F1	F2	H1	Геометрия / Обозначение пластины			Страница	
25	125	40	19	6.5	23	1		GY2M0475H040N-GU GY2M0500H040N-GU GY2M0475H030N-GS GY2M0500H030N-GS GY2M0475H040N-GM GY2M0500H040N-GM (калибровочная пластина) GY2G0475H020N-MF GY2G0475H040N-MF GY2G0475H080N-MF GY2G0500H020N-MF GY2G0500H040N-MF GY2G0500H080N-MF GY2G0524H020N-MF GY2M0500H040N-MS GY2M0500H080N-MS GY2M0500H040N-MM GY2M0500H080N-MM GY2M0475H238N-BM GY2M0500H250N-BM GY1G0475H020N-GFGS GY1G0500H020N-GFGS	F014 —016	
25	200	40	19	6.5	23	2				
32	140	50	22	6.0	30	3				
32	250	50	22	6.0	30	4				
40	150	60	28	8.0	37	3				
40	300	60	28	8.0	37	4				
40	150	60	28	8.0	37	3				
40	300	60	28	8.0	37	4				
40	150	60	28	8.0	37	3		GY2M0600J040N-GU GY2M0635J040N-GU GY2M0600J030N-GS GY2M0635J030N-GS GY2M0600J040N-GM (калибровочная пластина) GY2M0635J040N-GM GY2G0600J020N-MF GY2G0600J040N-MF GY2G0600J080N-MF GY2G0631J020N-MF GY2G0635J020N-MF GY2G0635J040N-MF GY2G0635J080N-MF GY2M0600J040N-MS GY2M0600J080N-MS GY2M0600J040N-MM GY2M0600J080N-MM GY2M0600J300N-BM GY2M0635J318N-BM	F014 —016	
50	170	80	34	9.0	47	3				
50	300	80	34	9.0	47	4				
40	150	60	28	8.0	37	3				
40	300	60	28	8.0	37	4				
50	170	80	34	9.0	47	3				
50	300	80	34	9.0	47	4				
50	300	80	34	9.0	47	4				

ТОЧЕНИЕ КАНАВОК

ОБОЗНАЧЕНИЕ > F012, F013
 РЕЖИМЫ РЕЗАНИЯ > F118
 ЗАПАСНЫЕ ЧАСТИ > M001